

China Chongqing 1 Plant

Exclusive system that can be used in parallel with existing oiler devices

Vacuum Roll System

❖ Press Washing Unit (USE Oiler Unit)

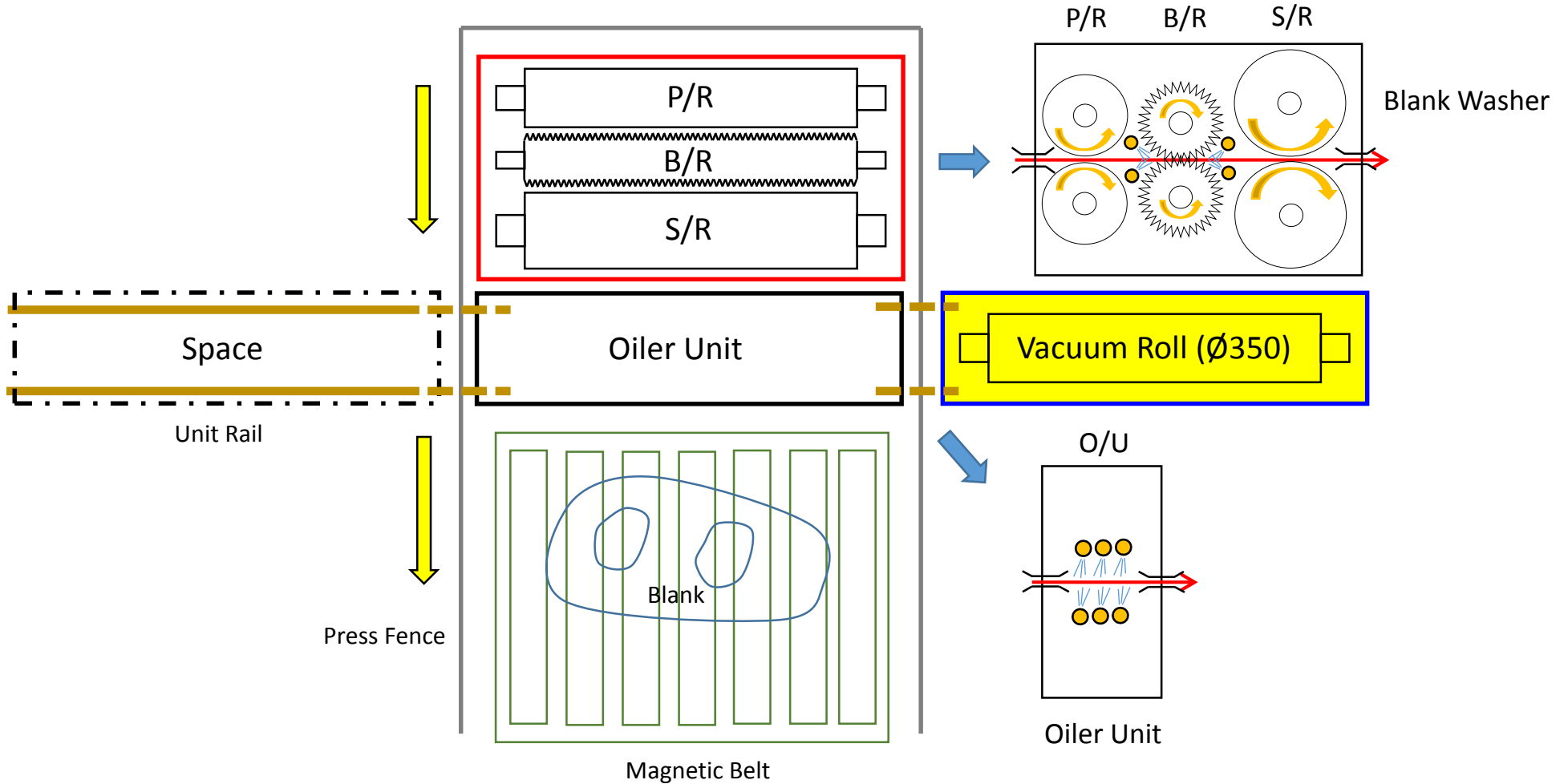

❖ Press Washing Unit (By Pass) :

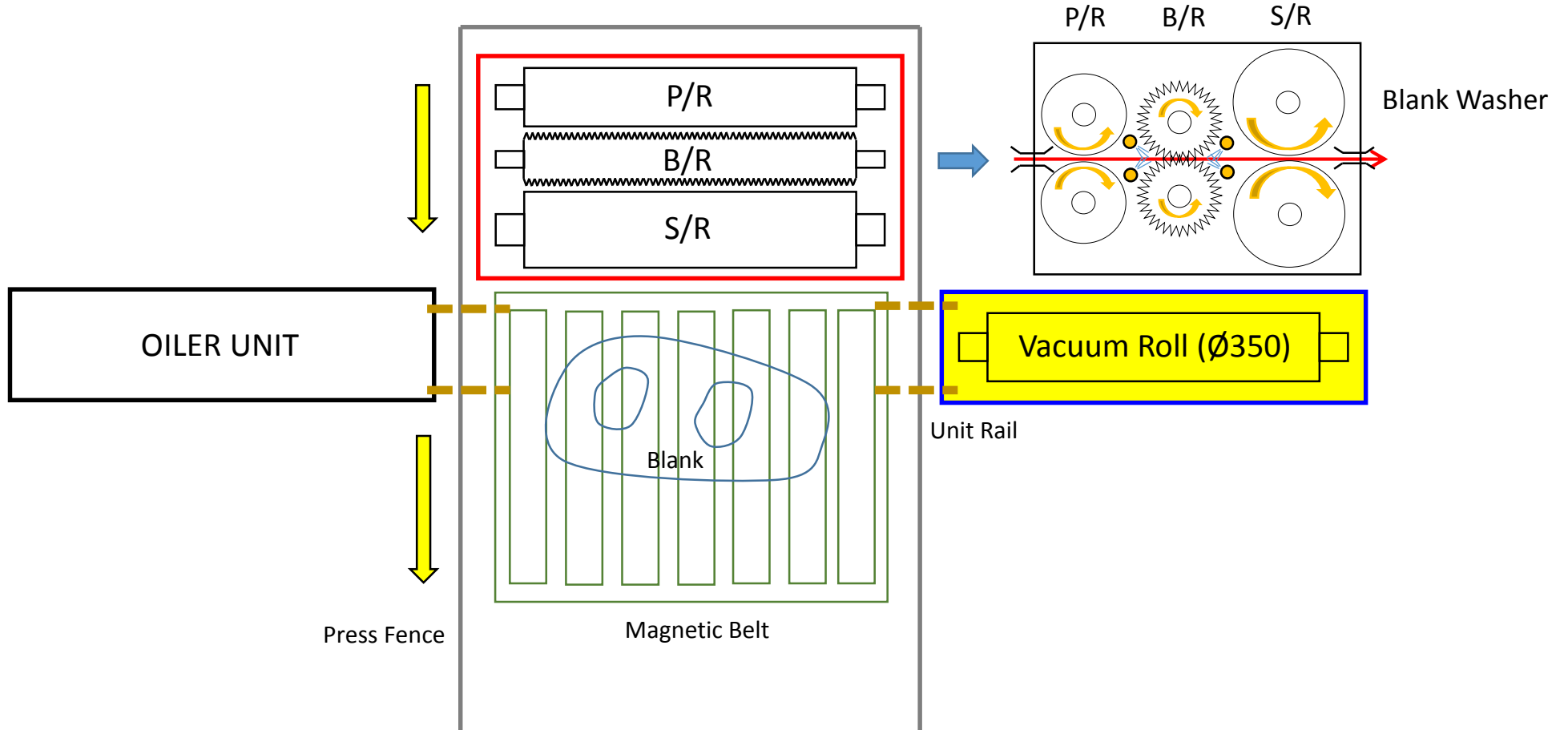

❖ Current Washer + Oiler Device Drawings

Name	Rev.	Drawn	Check	Approved	Date
Blank	01	J. Kim	J. Kim	J. Kim	2024.08.28
Blank	02	J. Kim	J. Kim	J. Kim	2024.08.28
Blank	03	J. Kim	J. Kim	J. Kim	2024.08.28
Blank	04	J. Kim	J. Kim	J. Kim	2024.08.28
Blank	05	J. Kim	J. Kim	J. Kim	2024.08.28
Blank	06	J. Kim	J. Kim	J. Kim	2024.08.28
Blank	07	J. Kim	J. Kim	J. Kim	2024.08.28
Blank	08	J. Kim	J. Kim	J. Kim	2024.08.28
Blank	09	J. Kim	J. Kim	J. Kim	2024.08.28
Blank	10	J. Kim	J. Kim	J. Kim	2024.08.28

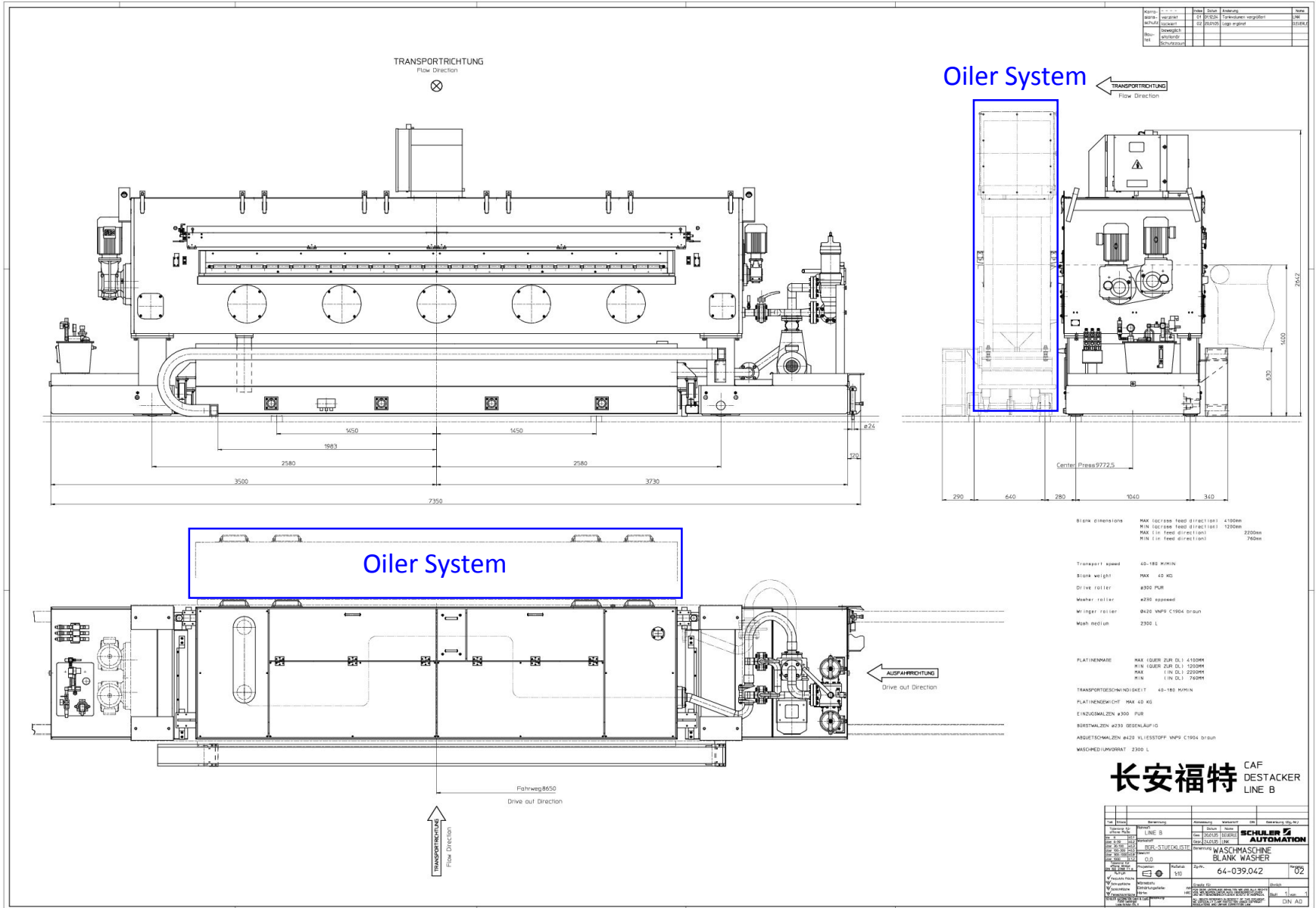

长安福特 CAF
DESTACKER
LINE B

Item	Description	Quantity	Unit	Material	Remarks
1	LINE B	1	Set		
2	DESTACKER	1	Set		
3	WASCHMASCHINE	1	Set		
4	BLANK WASCHER	1	Set		
5	64-039.042	1	Set		
6	02	1	Set		

❖ Exclusive Vacuum Roll System Drawings

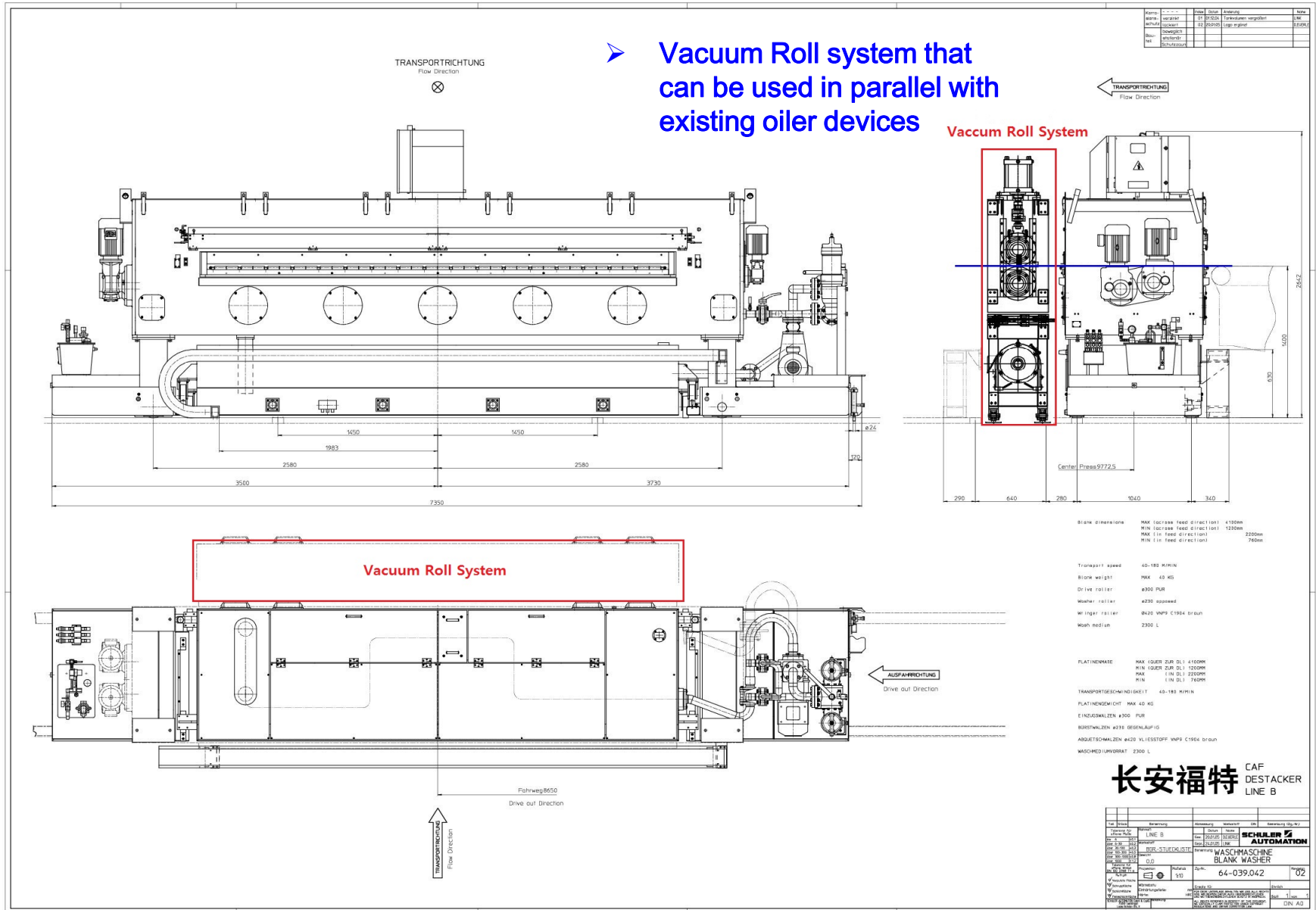

Thank You.